

Date	Rev	Record	Auth	ECN #	Reference
10/25/96	1	Update Border	MCM		
05/05/97	2	Update Part #	ML		
05/06/98	3	Add Rose Thickness Dimension	DH		
05/16/98	A	Add Alignment Hole	MCM		

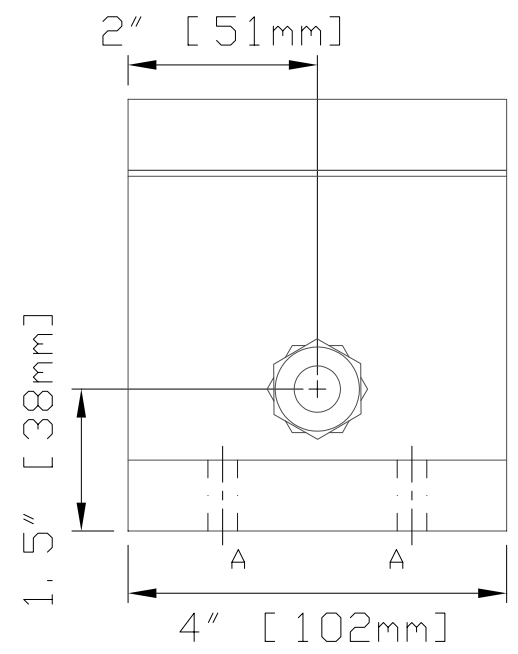
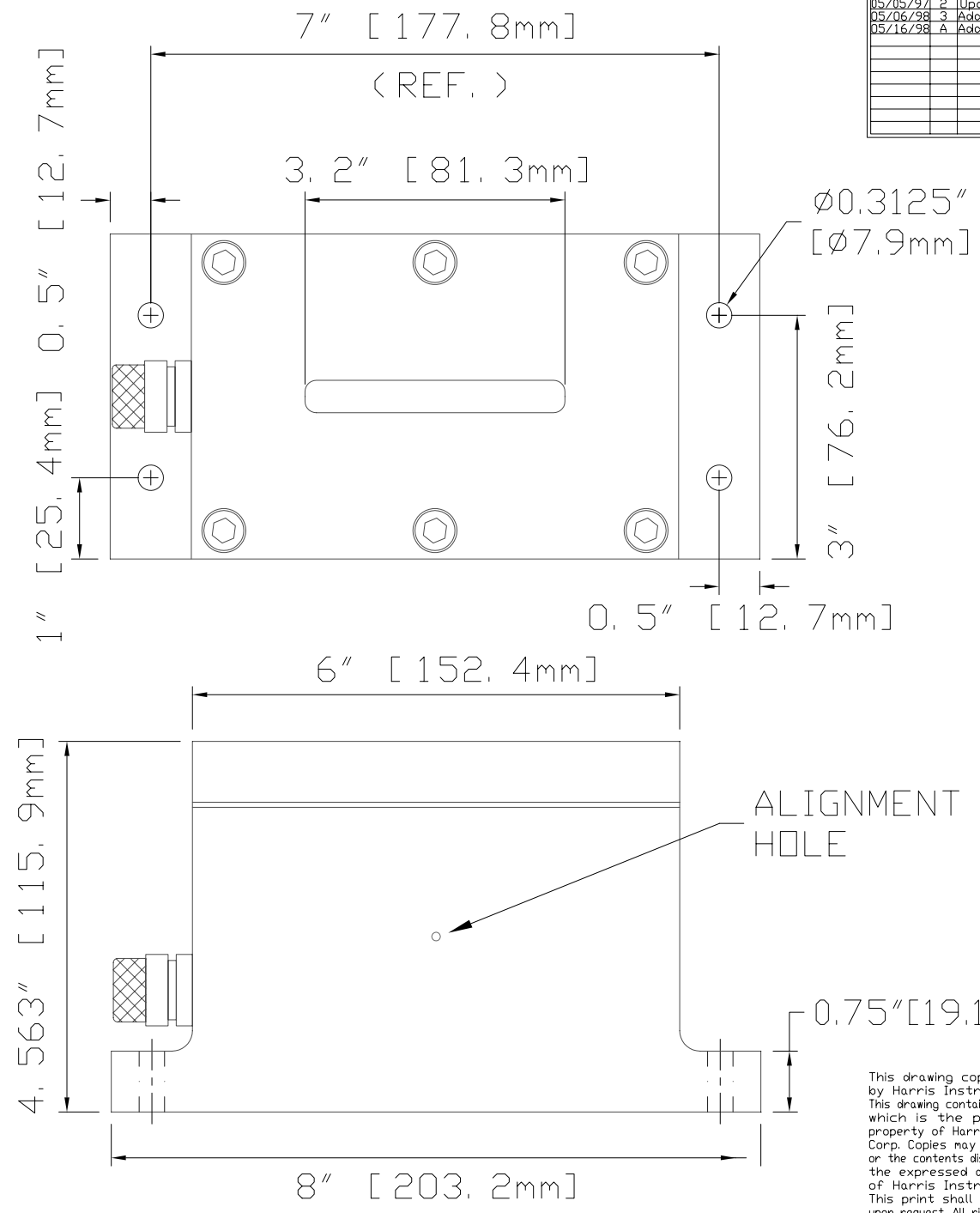

NOTE: LINEAR TOLERANCES ±0.010" [0.254MM] UNLESS NOTED. CUMULATIVE TOLERANCES NOT TO EXCEED 0.025" [0.625MM] UNLESS NOTED. HOLE TOLERANCES +0.010"/-0.000" [+0.025MM/-0MM] UNLESS NOTED. ANGULAR TOLERANCES NOT TO EXCEED 2° UNLESS NOTED.

HARRIS INSTRUMENT Corporation 155 Johnson Drive Delaware, Ohio 43015 U.S.A.						
Page 1/1	Size A	Scale 1:2	Drawn by MCM	Date 05/19/95	Approved by	Date
Part Revision A	DWG Revision 3	EVD # N/A	EPS # N/A	Standard Finish Blue Polane Paint	Assembly #	
Material Drawing Title Model EG-30A-UT Emitter Unit Dimensions				N/A Old Drawing # CA95028 Part # 1295028		

This drawing copyright 1997 by Harris Instrument Corp. This drawing contains information which is the proprietary property of Harris Instrument Corp. Copies may not be made or the contents disclosed beyond the expressed authorization of Harris Instrument Corp. This print shall be returned upon request. All rights reserved.