

Strip Entry Control System

Model TCPU
Level 3
with AZ Option

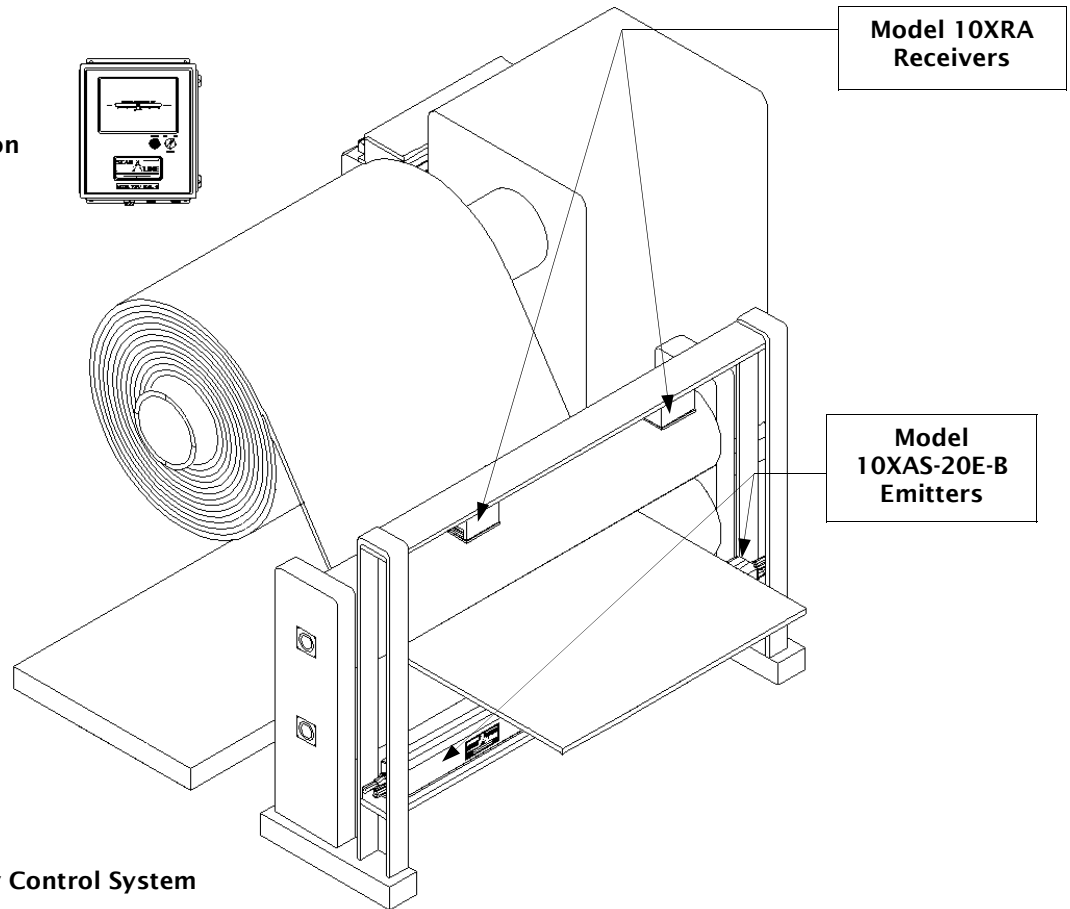

Strip Entry Control System

As part of a global economy, modern manufacturers experience a wide range of quality requirements for coiled products that must be processed to exacting standards. Improperly wrapped coils, poor product shape, neck-down, and edge damage can all slow the production process and consume narrow profit margins through excessive waste. Because of the unreliability of many earlier edge guide systems, some manufacturers have left entry guiding to manual operator control. The coarse adjustment to position produced by these manual corrections are reflected at the delivery end of the process.

The SCAN-A-LINE™ Strip Entry Control System (SEC System) should be one of the most important process control components on a coiled product line. It provides highly accurate material detection with an extremely quick response time for improved position control.

- Accurate to $\pm 0.005"$ [0.127mm] with linearity of $\pm 0.024"$ [0.6096mm] @ 2 sigma
- PID or Time Proportional Control
- Patented Scanned LED Technology
- Solid-state Reliability
- Dust, Mist, and Vibration Tolerant
- Easy to Install, Simple to Maintain
- Smart Sensor FAULT Detection Circuitry
- Clear or Translucent Material Position Control Available
- Several Analog Output Options Available
- First Edge Detection Available

Strip Entry Control System Components:

- PID Control Processing Unit Level Two or Level Three
- TPC Control Processing Unit Level Two or Level Three
- SCAN-A-LINE™ Sensors: 10XAS-Series Auto-Sync Sensors
- Up to 20 feet [6.1m] of cabling between the sensors and the processing unit

The SEC System supplies complete signal processing for up to two SCAN-A-LINE™ 10XAS-Series sensors. A smart sensor FAULT detector circuit monitors sensor signals for valid edge detection information. Defective scans due to strobe light or falling debris interference are rejected.

Strip Entry Control Processing Unit Features:

Proportional/Integral/Derivative (PID) Control Processing Unit-Model PCPU Level 2 or 3

Interfaces with most pneumatic or hydraulic proportional control valves or servo-valves in closed loop process control lines. The PID Control Amplifier (PID Module) in the Model PCPU provides a fully tunable deviation (bipolar) control signal. The Model PCPU Level 2 is designed for single-sensor systems while the Level 3 is designed for dual 10XAS-Series sensor systems.

Time Proportional Control (TPC) Control Processing Unit-Model TPCU Level 2 or 3

Available where no proportional or servo steering control valves are available. The TPC Controller supplies relay contact outputs to operate in parallel with existing manual jog switches. Relays close for a time proportional to position error (fully adjustable), as well as deadband control and transport delay. The Model TPCU Level 2 is designed for single-sensor systems while the Level 3 is designed for dual 10XAS-Series sensor systems.

Bargraph Display [All Models]

All Control Processing Units come standard with a Bargraph Display to visually represent the difference between a predetermined material position and the detected material position. Also included are annunciators and limit relays.

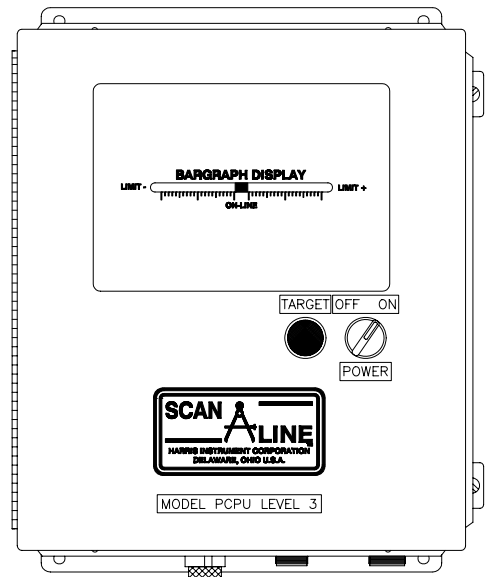

Model PCPU Level 3 with AZ Option

Analog Output Devices-DA3 Module or DA4 Module

Level 2 single-Sensor Analog Output Device (DA3 Module) provides fault-interrupted deviation (bipolar) analog output update with relay output for use in a single-sensor centerline guiding application. Absolute (unipolar) analog width output is also available.

Level 3 Dual-Sensor Analog Output Device (DA4 Module) includes three real-time analog outputs and three reference analog outputs. Required for Auto-Zero and LCR Option.

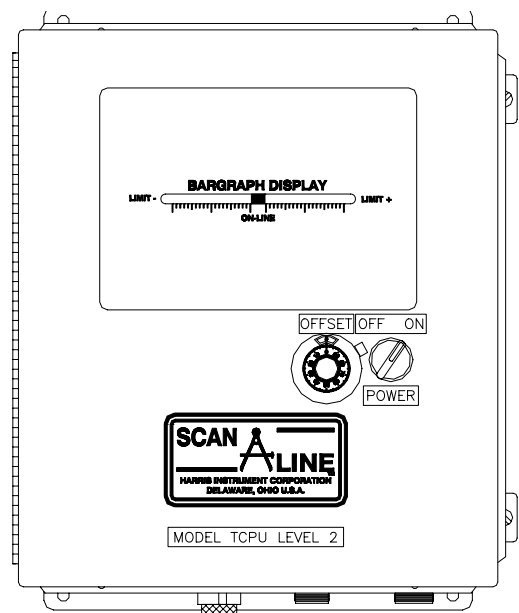

Model TPCU Level 2 with OP Option

Options for SEC System Processing Units:

Auto-Zero Push-button (AZ Option) provides the selection of any material position as a reference position. Fully compatible with PID Module and TPC Module, though not recommended with OP Option. The AZ Option is a momentary push-button mounted on door and may be mounted remotely (AZ50 Option). [Model PCPU Level 3 or Model TCPU Level 3 only.]

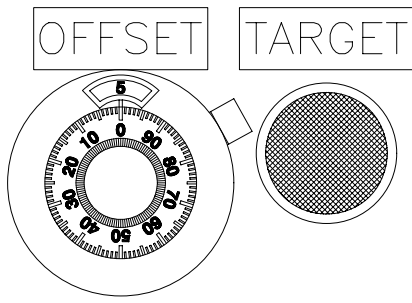

Control Offset Multi-dial (OP Option) allows operator to introduce a finely-tuned offset to the control signal for final material positioning. Fully compatible with Model PCPU and Model TCPU (not recommended with AZ Option). Control Offset Multi-dial is also available in a remote mount configuration.

Left/Center/Right Selector (LCR Option) provides a means of selecting the desired guide point for automatic control. Flexible selection of the left edge, right edge, or centerline of the material as a guide position. May be remotely mounted (LCR/50 Option). Model PCPU Level 3 and Model TCPU Level 3 only.

Line Driver/Receiver (LDR Option) connects a Control Processing Unit with another processing unit (such as a Model GPU Level2). This becomes necessary when 10XAS-Series sensors for the system must be located more than fifty linear cable feet [15m] from the processing unit. Maximum operational distance is 4000 linear cable feet [1200m]. Compatible with all Control Processing Unit features and options.

4/20mA Current Loop (4/20 Option) provides an isolated, long distance routing of analog signals from the Control Processing Unit to a PLC (or other analog input device).

Remote Bargraph Display (BGA/50 Option) utilizes the Bargraph Display normally mounted on the front door of the Control Processing Unit, allowing mounting of the display up to fifty linear cable feet [15m] from the processing unit.

First Edge Video Pre-Processor (FEV Option) detects first edge viewed as the first edge of material, ignoring all other edges. Model PCPU Level 3 and Model TCPU Level 3 only.

SCAN-A-LINE™ 10XAS-Series Sensors:

- High-speed edge position tracking for proportional position control
- Precise 2000 inch [508cm] per second scan velocity
- Position information is a function of time rather than light intensity
- Quartz Crystal controlled-won't drift out of adjustment
- Smoke, steam, dust and dirt have no effect on edge detection
- Nothing to burn out and NO MOVING PARTS mean virtually no maintenance worries
- LED's rated at 275-year mean-time-between-failure (MTBF) and carry a lifetime guarantee

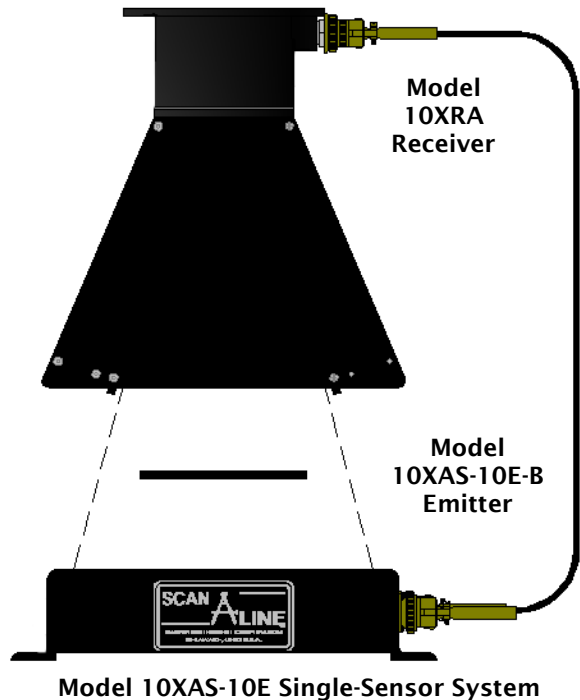

SCAN-A-LINE™ 10XAS-Series Auto-Sync sensors allow for the greatest position size variation in material guiding. They may be configured as a single-sensor or dual-sensor system, depending upon the size of the material to be guided, without any special hardware. 10XAS-Series sensors come in ten inch [25.4cm] increment lengths ranging from ten inches [25.4cm] up to forty inches [101.6cm].

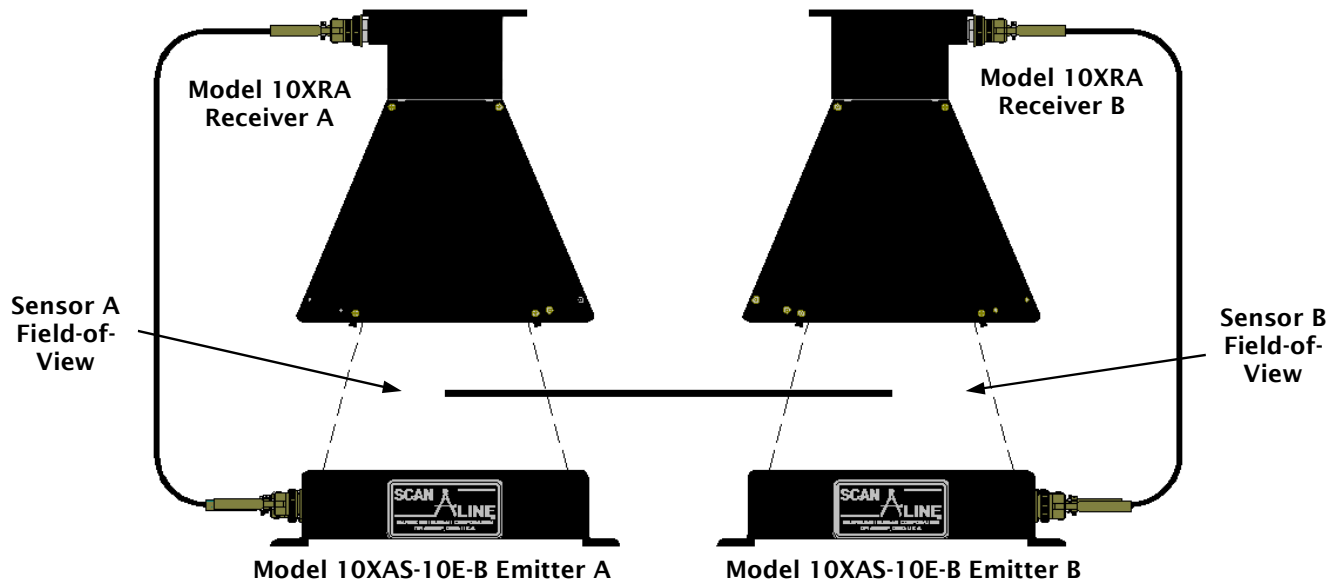

10XAS-Series Dual-Sensor System

10XAS-Series Single-Sensor System includes one emitter, one receiver, and up to twenty feet [6.1 m] of interconnection cabling. A single-sensor system can accommodate materials measuring between one-half inch [12.7mm] and thirty-eight inches [96.5cm]. Single-sensor systems require the use of the Model PCPU Level 2 or Model TCPU Level 2 for conversion of the digital sensor signal into analog control signal for interfacing with process line controls.

10XAS-Series Dual-Sensor System includes two emitters, two receivers and up to twenty feet [6.1 m] of interconnection cabling. A dual-sensor system can accommodate materials measuring between six inches and up to an almost infinite maximum size (Note: if guiding materials both narrow and wide, overall maximum material width may be limited.) Dual-sensor systems require the use of the Model PCPU Level 3 or Model TCPU Level 3 for conversion of the digital sensor signals into analog control signal for interfacing with process line controls.

Options for SEC System Sensors:

- Infrared LED (IR Option): Designed for operation in extremely hazy conditions that attenuate material detection. Also used for visible light intolerant materials.
- ULTRA-TOUGH™ enclosures (UT Option): For applications where physical abuse and damage cannot be avoided.
- On-Line Balance (OLB Option): Allows sensor to be balanced on-line for peak performance.
- Clear Material (CLR Option): Provides for detection of clear, translucent or loosely woven products (requires On-Line Balance Option).
- End Alignment (EA Configuration): Designed for measurement applications where product thickness varies.



Model 10XAS-10E-UT Emitter



Model 10XAS-10E-B Emitter



Harris Instrument Corporation
 155 Johnson Drive Delaware, OH 43015
 Voice: 740-369-3580 Fax: 740-369-2653
 info@harris-instrument.com www.harris-instrument.com